

AP Workbook

APVolution Z



Table of Contents	Pages
1. Overview	2
2. Instructions about Press & Layering Porcelain	4-6
3. Instruction for the Press Technique-Ingots Press & Layering Technique for APVolution Z	7
4. Press & Staining Technique for APVolution Z	8
5. Zirconia Framework Preparation	9
6. Application of the OccluMaster Wax Patterns	10-11
7. Spruing Rules	12-14
8. AP Investment - Easy Vest Speed	15-20
9. Divesting Procedure	21-22
10. Internal Staining Technique	23-26
11. Porcelain Powders	27
12. Layering Technique in Detail	28-29
13. Gingiva Shades	30
14. Overview of Colors & Firing Charts	31
15. Technical Data	34
16. Warnings	35

Overview

Aesthetic-Press™ APVolution Z

Porcelain to Zirconia

Press to Zirconia



Layering Powder



2. Instructions About Press & Layering Porcelain

Material and Indication, Contraindication

The Aesthetic-Press layering ceramic APVolution Z is based on silicate sintered glass ceramic and is colored according to the Vita classical shade guide A1-D4.

The APVolution Z layering ceramic is only intended for dental applications and for use by trained professionals. A matching transparency and fluorescence allows the reconstruction of natural looking teeth in the form of all-ceramic crowns or bridges made of tetragonal stabilised zirconia (YTZP) with a chemical expansion of $10.6 \times 10^{-6} \times K^{-1}$ (25- 500 °C).

Contraindications:

- Combinations with ceramic materials outside of Aesthetic-Press's described range of product systems and/or material from another manufacturer.
- Use of non-approved framework materials.
- Sharp edges and corners on the framework or non-anatomically reduced frame shapes.
- Dental ceramic and complete ceramic restorations made of glass ceramics are not recommended for patients with bruxism or parafunction.

Fabrication of Framework

The fabrication of zirconia framework (CAD, CAM, sintering, surface treatment, cleaning) must be performed according to the manufacturer's instructions. The framework must have a reduced anatomical shape and should provide enough space for an even coating of layering ceramic < 2 mm. Sharp edges and corners need to be rounded off.

It is important to prepare the zirconia framework with a slightly rough surface. Using coarse diamond burs and the light use of alumina oxide and sandblasting will prepare the zirconia frame correctly before the application of the porcelain, whether layered or pressed onto.

Dentin Bake on Zirconia

Mix the ceramic powder (Dentin and/or Incisal) with the AP modeling liquid to a creamy consistency. The modeling liquid will lead to a more homogenous porcelain powder for the build up. By keeping all the color particles together, the build up liquid will lead to more vital colors. Regular water/distilled water is not recommended.

1st Bake

After the Dentin application the crown should be placed on a firing tray with a starting temperature of 400 °C.

The time to close the furnace can be set between 4 to 6 minutes with a rising temperature of 45 °C/min with vacuum (vacuum starting at 450° C) to 780°. Hold time: 1 minute without vacuum.

For multiple-unit bridges, if needed increase the firing temperature about 10-15°C. **Always evaluate the results after firing. Please note, that the porcelain surface should look a little bit granular. Make sure not to overheat the porcelain, which would lead to an overly glossy surface.**

After the first Dentin/Incisal firing is complete, it is indicated to use either diamond burs or a green stone to shape the porcelain crown or bridge. After thoroughly cleaning the surface with a steam cleaner, the application of the porcelain using Dentin, Enamel or Transpa Powders can continue to complete the restoration and anatomy.

2nd Bake

Same procedure as the first Dentin firing, except with a firing temperature of about 10° C lower than the previous bake. (evaluate the result after firing)

Glaze Finish/ Glaze Bake on Zirconia

After completely finishing the surface with a diamond instrument, thoroughly clean the crown and bridge. Glaze bake of layered crowns and bridges with AP Glaze Paste, AP Chroma Shades, is carried out at temperatures of 740 °C-760 °C (please note that temperatures can vary in different oven models).

Glaze Bake

After the glaze application, place the crown on a firing tray at a starting temperature of 400 °C. Subsequently close the furnace with a 4-minute closing time and then heat at a rate of 45 °C without vacuum to 750 °C. Hold time is 1 minute without vacuum.

For full-contour crowns and bridges made of Y-TZP, the firing temperature may be increased up to 800 °C, depending on the desired surface aspect.

Color Combinations and Firing Table

Note:

The firing temperatures were determined in a Dekema press-i-dent furnace. For other furnaces, corrections to the firing temperatures may be necessary.

Color comb.		A					B				C				D		
VITA Shades		1	2	3	3.5	4	1	2	3	4	1	2	3	4	2	3	4
AP	Dentin	A1	A2	A3	A3.5	A4	B1	B2	B3	B4	C1	C2	C3	C4	D2	D3	D4
AP	Incisal	Enamel 1		Enamel 2			Enamel 1		Enamel 2		Enamel 1		Enamel 2		E 1	Enamel 2	

Firing Chart (°C / on zirconia)

Firing Chart Powder Porcelain	Pre-heat Time	Idle Temp	1st Bake	2nd Bake	Heat Rate increase	Vac On	Hold Time	Long term cooling
Dentin / Incisal	4 min	400 °C	780 °C**	770 °C**	45 °C/ min	450 °C	1 min	500 °C
Glaze, Stains, Shades	4 min	400 °C	750 °C	750 °C	45 °C/ min	-	1 min	500 °C
Correction Powder	4 min	400 °C	720		45 °C/ min	450	1 min	500 °C

** Firing temperature depends on the number of units in the furnace. More units require up to **20-30° C** higher firing temperature. **Keep in mind that these temperatures are recommendations and may vary in different ovens!**

*VITA is a registered trade mark of the VITA- Zahnfabrik, Bad Säckingen

3. Instruction for the Press Technique Ingots

Press & Layering Technique for APVolution Z

These dentin shades are available as powder porcelain to layer and/or as ingots for the press technique!

Vita Shades*	A1	A2	A3	A3.5	A4	B1	B2	B3	B4	C1	C2	C3	C4	D2	D3	D4
APVolution Z Dentin Ingots	A1	A2	A3	A3.5	A4	B1	B2	B3	B4	C1	C2	C3	C4	D2	D3	D4

The master kit consists of the following powders to cover the following dentin shades: A1,A2, A3, A3.5,A4, B1, B2, B3, B4,C1,C2, C3,C4, D2,D3, D4.

The AP System enables achieving all 16 shades in an economic way. For the press and layering technique, the High Chroma Bleach ingot covers bright shades.



Each powder bottle comes with a "scoop" to measure a precise amount for layering porcelain.



A powder master kit is available a la carte. All of the 16 dentin shades, three value-based shades two bleach and one gingiva shade are available next to 14 enamel transpa and opalescent powders.

4. Press & Staining Technique for APVolution Z

Ingot Selection

The AP Value System enables the technician to streamline production and make every step within the workflow of the press technique far more efficient than the traditional system. The APValue System consists of three most important colors defined by value:

- Light
- Dark
- Dark Plus

For the press and staining technique, three different values are available to achieve the 16 Vita Shades.

Press & Staining Technique Aesthetic-Press™ Value Based System

Ingot Selection for Press & Stain Technique	
VITA Shades	Aesthetic-Press Product Name
A1, B1, C1, D1	APVolution Z Light
A2, B2, C2, D2	APVolution Z Medium
A3, A3.5, B3, C3, D3	APVolution Z Dark
A4, B4, C4, D4	APVolution Z Dark Plus
Bleach Shades	APVolution Z Bleach 1, 2, 3
Gingiva	APVolution Z Gingiva 1-8

All ingots are available in 2 g and 3 g

Press Program APVolution Z			please note: the recommended firing temperatures can vary!		
Idle	Rising Temp	End Temp	Hold Time	Vac on	Ring size
700 °C	65 °C	820 °C	20 min	700 °C	200 g
700 °C	65 °C	830 °C	20 min	700 °C	300 g
700 °C	65 °C	860 °C	40 min	700 °C	400 g

5. Zirconia Framework Preparation

Sandblast yes—no liner needed!

To achieve the right bonding between the AP porcelain and a zirconia coping, it is not necessary to apply a liner. After fitting the coping to the die, the coping can be treated with 110 microns of alumina oxide using 2-3 bars of pressure. Since there is no chemical bond between the porcelain and the zirconia surface, it is indicated to prepare the zirconia surface with a certain surface micro-roughness.

Do not rubber wheel or smoothen the surface before the application of porcelain. This can lead to a potential delamination.



6. Application of the OccluMaster Wax Patterns



The right way to use the prefabricated wax patterns is to hold the wax pattern at the sprue while using a hair dryer warming up the wax pattern very gently from each side. (Pic 2) The warm air will make the wax pattern more flexible in order to adapt it properly to the die or the coping.

Using the OccluMaster for full ceramic crowns, the die needs to be covered with a solid coat of wax. After applying the wax coping, the wax pattern can be adapted to the die and put into occlusion. Once the wax pattern is positioned on the die, it is important to seal the margins in order to guarantee a solid positioning of the wax pattern.

Before closing the articulator and bringing the OccluMaster into occlusion, it is important to warm up the entire wax pattern again to make sure that the occlusal form adapts in the right way to the opposing dentition.

Final correction of the anatomy can be done with little effort to achieve the desired form and function.



The zirconia copings show average occl. clearance.



Warming up the wax patterns with a hair dryer.



The OccluMaster in final position



Occlusal details can be adjusted with a sharp instrument



Wax patterns after occlusal adjustments

7. Spruing Rules

Problem: In many different spruing instructions for use available, state that there are rules "must comply" regarding spruing techniques.

SOLUTION: According to my experience some of the complied rules regarding spruing objects are good, but not absolutely necessary.

Introduction

The results, of working with the press ceramic by Aesthetic Press (San Francisco, USA), put clear that some rules when spruing objects are not absolutely necessary. When spruing objects, there are basically the following parameters, which should be considered and discussed.

- Length
- Diameter
- Angel
- Shape

The length of the sprue can be between 0.3 mm to several inches.

Figures 1 and 2 show examples of which one can already see at first glance the press result from the long sprues, which may well be longer than expected. Thus the lengths of sprues during pressing, using pink ingots (Aesthetic Press) are several inches long. Also subsequent pressing of the white portions illustrate the dynamic possibilities.

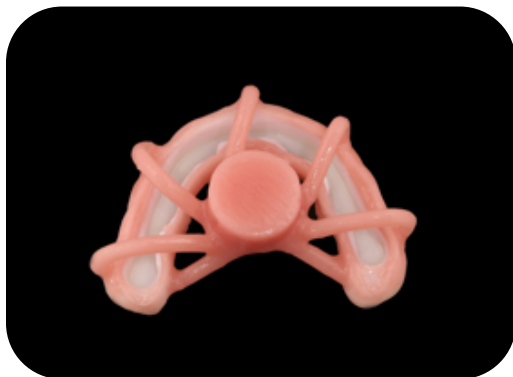

in this example, 6 x 2.5 g pink pellets pressed together



in the second step, white portions pressed together

After years of experience, the author uses 0.3cm - 3 cm sprue length to obtain these possibilities.

The diameter of the sprues should be 3 mm or gauge 8

One can say that there is no compulsory fixed angle rule. Figure 1 pressed in pink ceramic illustrates the sprues going up and down rapping around the object justifying the particularly good pressing properties of the AP-pressed ceramic enabling difficult cases possible.

In general, one can maintain the length of the sprues as short as possible for minimal material usage.

Since there is no minimal sprue length required, it is safer when cutting the sprues to have at least a 2 mm distance to the crown. This will avoid excessive heat in cuspal regions, which can cause cracks.

The most important fundamental rule is to keep the sprues clean and smooth. Poorly unfinished waxed up areas increase the risk of investment embedding into the ceramic. Spruing angles can easily from 30- 90 degrees

Angulation of Sprues: 45 degrees are ideal but not mandatory!

The sprues should be placed at the edge of the main plunger channel stand. This enables the object to be in the warmer region of the muffle. Sprued objects in the middle of the plunger stand are more prone to a faulty pressing, since the temperature in this area is cooler.

The distance of the crown to the mold bottom or the walls should be at least 0.75 cm (fig. 3).

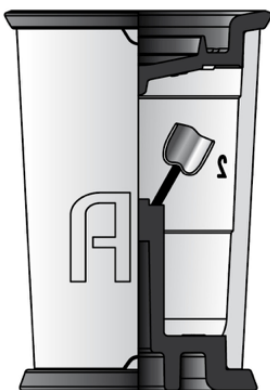

Recommended angle for single units

A posterior bridge with molars

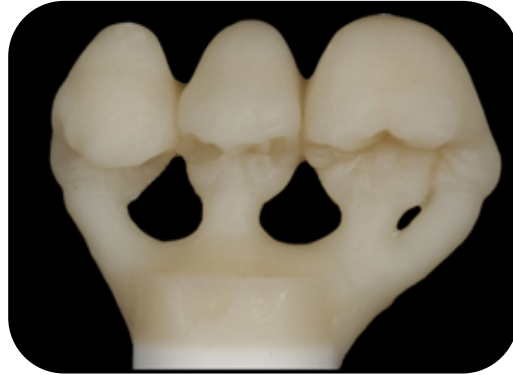

Clean spruing allows for a good pressing result

Tips how to press implant crowns

To successfully press implant crowns, it is necessary to use the metal pins of the honey-comb firing tray. They will stabilize the die in the investment, since the diameter of the implant crown is often times quite thin, which may lead to fracture if unsupported!



Conclusion

Correct spruing justifies good homogeneous results in the press technology. Many believed rules as previously mentioned i.e. sprue angles, are not a compulsory necessity. Common sense and the need for simplicity often offer the right answer to frequently asked questions.

8. AP Investment - Easy Vest Speed



Speed Investment for all pressable ceramics and all dental alloys

The AP Phosphate Bonded Investment material was developed for the crown and bridge techniques. AP offers this high tech type of investment material for Hi-Noble and long-span superstructures to non-precious and pressable investments. The Easy-Vest is an extremely high-quality product, which has been specifically designed to produce consistently accurate castings and due to the fine material, the castings/press units show a smooth surface which is important for the fit of metal frames and pressed porcelains.

Mixing ratio: 25 ml Liquid to 100 Gramm Powder

General Rules:

The higher the liquid concentration, the more expansion will be achieved.

Keep mixing bowl clean and slightly moist before use- Do not wipe with towel!

Procedure for casting alloy:

It is suggested to premix the investment 15 seconds by hand first before mixing under vacuum for 60 seconds.

Metal Casting Ring: 1 layer for flask liner for small ring, size X 1+3
2 layers for flask liner for large ring, size X 6+9

How to use the speed technique:

After investing it is required to wait 30 minutes before placing the ring into the preheated oven. The temperature should be around 850-900 ° C depending on alloy. This rule applies to rings with a metal ring surrounded.

Metal free rings can be placed in the oven after a 15 min bench set time.

Holding Times:

Small ring: 45 min

Large ring: 60 min

Add additional 10min for multiple rings in the furnace

Mixing Ratio for Speed Investment:

Pressable ceramics	100 g 12.5 Liquid - 12.5 Water	200 g 25 ml Liquid - 25ml Water	300 g 37.5 ml Liquid - 37.5ml Water
Gold Crowns	100 g 14.5 Liquid - 10.5 Water	200 g 29 ml Liquid - 21 ml Water	300 g 43.5 ml Liquid - 31.5 ml Water
Bridges high noble noble alloys	100 g 16 ml Liquid - 9 ml Water	200 g 25 ml Liquid - 25 ml Water	300 g 48 ml Liquid - 27 ml Water
Non precious base alloys	100 g 23 ml Liquid- 2 ml Water	200 g 46 ml Liquid- 4 ml Water	300 g 69 ml Liquid- 6 ml Water
Lithium/ Silicate reinforced	100 g 22.5 ml Liquid - 2.5 ml Water	200g 45 ml Liquid - 5 ml Water	300g 67.5 ml Liquid - 7.5 ml Water

Investing procedure for pressable ceramics:

It is suggested to mix the investment 15 seconds by hand first before mixing under vacuum for 60 seconds.

Bench Set Time:

After investing it is required to wait 15 min before placing the ring in the preheated furnace. (850° C)

Holding times:

200 g ring 45min

300 g ring 60min

Important Note:

1. Investment contains silica – avoid inhaling dust.
2. Do not open furnace during burn out phase – wax steams might catch fire in the air.

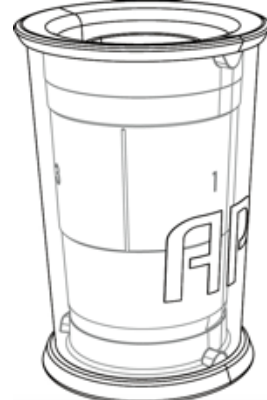
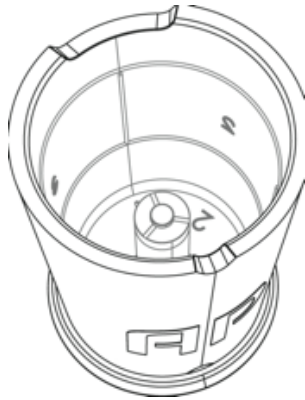

Simple spruing angulation for single units. place sprue straight onto the incisal edge.

Choose this angulation for posterior bridges to avoid bubbles on the occlusion.

The AP investment rings show their numbered section on the bottom part, on the inside of the ring and on the top part. Aligning units always starts from sector one. This will help to shorten the divest cycle. It is important to know where the invested units are, so one can trim the pressed ring in various directions.

After mixing the investment for 60 seconds under vacuum, the Easy Vest shows a nice flow characteristic. Filling up the ring can be done rapidly without fearing of bubbles. The key to a nice and clean result lies in the angulation of the to be pressed units.



keep the angulation open to avoid bubbles



pour the investment between the upper line and the upper edge of the ring



The lid of the investment ring closes in only one position. Place the lid firm onto the rubber ring and let the excess material flow through the excess holes. Remove lid and ring after 15 min bench set time.

Due to the tapered geometry, the set investment will be released effortlessly. Clean the rubber immediately, since due the warmth of the investment material, the rubber is soft and easy to clean!



The 200 g ring with the bottom and top part.



The plunger maker can be filled with the investment material used to invest the regular units. Make sure not to use high expansion ratios. A 50% expansion ratio for the press over porcelain and respectively the plungers are recommended.

The AP 400g ring

This ring is designed to be able to press full arch cases, such as large implant cases. Alternatively, the AP 400g ring is ideal for large operations to reduce the invest- burn out- press & divest up to procedures. The time savings are up to 50%, which saves time and money. With the ability to press up to 20 units and up to 30 g of porcelain, this ring is unique and can be used for any furnace in the



make sure to sprue all posteriors from buccal and lingual



anterior are pressed in dentin ingot for layering, posteriors in classic light ingot for staining



9. AP investment rings made to divest efficiently

Align units always starting from sector one (see page 17). This will help to shorten the divest cycle. It is important to know where the invested units are, so one can trim the pressed ring in various directions.



After the press cycle, remove the ring quickly out of the furnace. Place the hot ring at a safe location away from the press furnace to cool. The metal ring will oxidize outside the furnace, which might cause some metal particles to show.

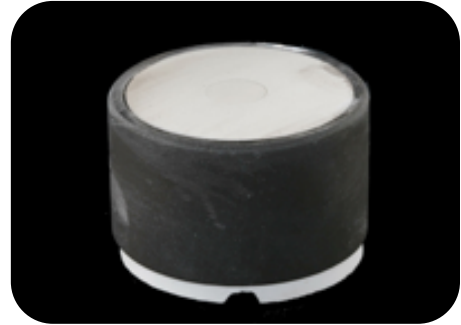

The quickest way to divest is to trim the ring up to the edge of the safety belt. A model trimmer, weather wet or dry can be used for this procedure.



The ring shows the reduction, which is right at the midline of the AP 200 ring in this case. The reduction for the AP 300g and the AP 400g ring follows the same procedure.



Since the invested units are in sector one, the ring will be trimmed from the back on the opposite side. It is apparent how quickly the units will be released from the investment material. With just a short amount of sand-blasting, the invested crowns will be clean and ready to process.



It is recommended to use 50 microns of glass beads and about 2- 3 bar of air pressure.



With just a short amount of sandblasting, the invested crowns will be clean and ready to process.

10. Internal Staining Technique



The anterior restoration has been fit on the model after the diagnostic wax up has been pressed with the Dentin A1 ingots.



A precise reduction for the enamel and transpa layers is cut from the incisal edge all the way to the margin. The goal is that all the stains are on the inside of the crown and not too much on the surface. This way, a better surface texture can be achieved as well.



At the mesial corner, a touch of blue stain is added to create translucent effects.



In order to create some contrast within the color scheme and to highlight the mesial ridge, white stain is placed to increase the value



The stain kit from Aesthetic-Press offers a fluorescent paste, which has a wide temperature range for Low Fusing porcelains and up to High Fusing temperatures. The temperature can range between 750° C to 930° C



Even for full zirconia crowns the paste offers a wide range of options to achieve lifelike and matching colors.

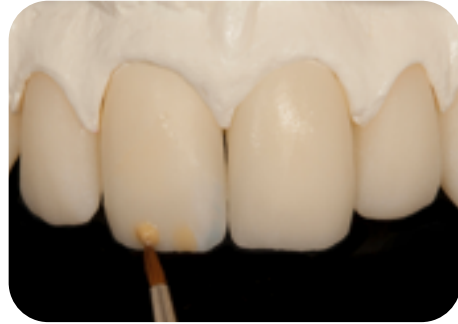
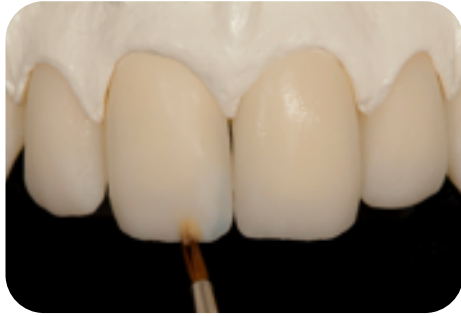

Mamelon stains are used to match the incisal characteristics. The intense orange can be placed on the right place with the desired intensity. This technique is by far more controlled and predictable. This will lead the technician to a successful result, with no shrinkage or color surprises



Much like on the mesial, the distal line angle will be highlighted with the white stain. Distally, a soft tone of translucent blue is added. Often these characteristics should reflect the ones shown by the lower incisors.



The margin stain is added to the cervical area to avoid a too translucent areas especially due to thin porcelain thickness.



With just one staining cycle, it is possible to achieve a most lifelike result with the Fluorescent Effect Stains and the Mamelon Stains.

11. Porcelain Powders

APVolution Z

The **APVolution Z** Enamel, Transpa & Opalescent Powders are available:

APVolution Z						
T Opal 1	T Opal 2	Opal Enamel 1	Opal Enamel 2	Opal Enamel 3	Enamel1	Enamel 2
T-Clear	T-White	T-Yellow	T-Blue	T-Orange	T-Amber	T-Pink

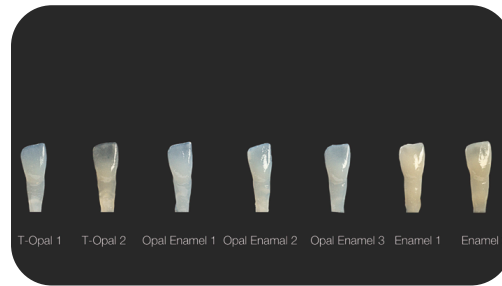

The indicators show the color and the variety of appearance with different thicknesses. These indicators are all handmade and individually finished. It is our recommendation for every technician to fabricate such indicators to truly understand the porcelain used. This will also allow to really compare the individual brands on the market.

12. Layering Technique in Detail:

Once the first bake has been established or alternatively the Dentin core has been pressed with the Aesthetic Press APVolution Z ingot onto the zirconia frame, the technician can layer with a selection of enamel and transpa or opalescent materials. Once the dentin core has been established and the internal characteristic are defined with the internal staining technique, the powders can now complete the tooth the the desired anatomical form.

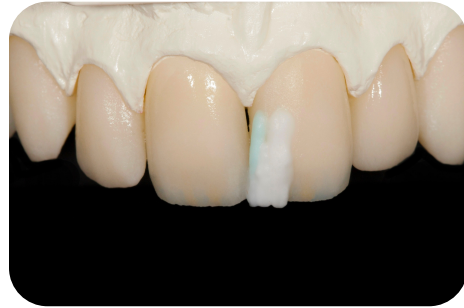
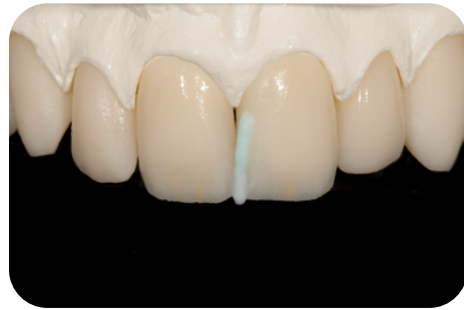
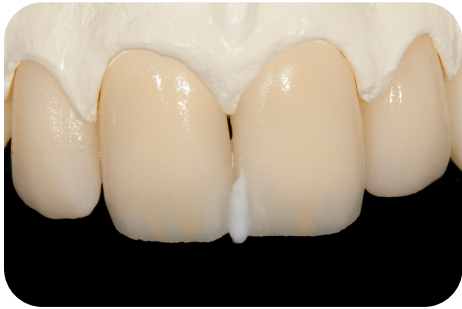

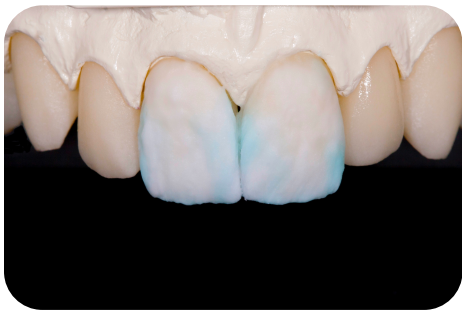
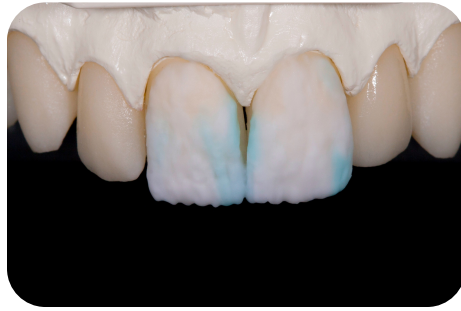
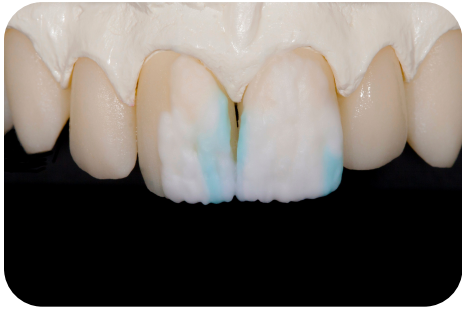

13. The following Gingiva shades are available:



14. Overview of color and firing charts

Firing Chart Powder Porcelain	Closing Time	Idle Temp	1st Bake	2nd Bake	Heat Rate	Vac On	Hold Time	Cooling*
Dentin / Incisal	6 min	400°C	780°C*	775°C*	45°C/min	450°C	1 min	450-600°C
Glaze, Stains, Shades	6 min	400°C	775°C	750°C	45°C/min	450°C	1 min	450-600°C

*Long span bridges should see a slow cool down to 450°C before oven chamber opens.

Color comb. for Powders	A				B				C				D			
VITA Shades	1	2	3	3.5	4	1	2	3	4	1	2	3	4	2	3	4
AP Dentin	1	2	3	3.5	4	1	2	3	4	1	2	3	4	2	3	4
AP Incisal	Enamel 1		Enamel 2			Enamel 1		Enamel 2		Enamel 1		Enamel 2		E 1	Enamel 2	

Press Program APVolution Z							add. function	add. function
Idle	Rising Temp	End Temp	Hold Time	Vac on	Vac off	Ring size	Dekema Press Level	Ivoclar Stop Speed - E
700	65	820°C	20	700°C	820°C	200g	L5	50
700	65	830°C	20	700°C	830°C	300g	L5	50
700	65	860°C	40	700°C	860°C	400g	L7	50

*Warning: Temperatures can vary in different ovens up to 40°C or more. It is recommended to observe the results and adjust the parameters accordingly. For questions please contact the AP office : Ph +1 415.692.5362 or email: info@apdental.net

VITA Shades	Aesthetic Press Shade System	Aesthetic Press Product Name
A1, B1, C1, D1	Light	APVolution Z Light
A2, B2, C2, D2	Medium	APVolution Z Medium
A3, A3.5, B3, C3, C3, D3	Dark	APVolution Z Dark
A4, B4, C4, D4	Dark Plus	APVolution Z Dark Plus
Bleach Shades 010-040	Bleach 1,2,3	APVolution Z Bleach 1,2,3

Ingot Selection for Press & Stain Technique		
VITA Shades	Aesthetic Press Shade System	Aesthetic Press Product Name
Gingiva	Gingiva 1-8	Gingiva 1-8

Ingot Selection for Press & Layering Technique																	
Color comb. for Ingots		A				B				C				D			
VITA Shades		1	2	3	3.5	4	1	2	3	4	1	2	3	4	2	3	4
AP	Dentin	1	2	3	3.5	4	1	2	3	4	1	2	3	4	2	3	4

15. Technical Data

Material information:
 Material: silicate glass ceramic
 Chemical composition: mayor components bonded to the glass ceramic structure

 $SiO_2, Al_2O_3, K_2O, Na_2O, CaO, B_2O_3$

 Classification acc. DIN ISO 6872:2015

APVolution Z Powder		APVolution Z Ingots	
Type: 1	Class: 2a	Type: 2	Class: 2a
Classification acc. DIN EN ISO 6872:2015			

Zircon Dentin

Coefficient of thermal expansion	DIN EN ISO 6872	2 bakes:	$9.0 \times 10^{-6} \times K^{-1}$
		4 bakes:	$9.0 \times 10^{-6} \times K^{-1}$

Classification acc. DIN EN ISO 6872:2015

Zirconia AP Glaze, AP Stains, AP Shades

Coefficiency of thermal expansion	DIN EN ISO 6872	$12.5 \times 10^{-6} \times K^{-1}$
Transformation Temperature	DIN EN ISO 6872	435°C

16. Warnings

Only to be used by trained personnel

When working on ceramic restorations safety glasses should be used. Remove dust and fragments by suction.

Be careful of high firing and pressing temperatures. Danger of getting burnt! Use oven pincers and gloves!

Due to the different ceramic ovens available on the market, the firing conditions may differ. This must be taken into account and is under the responsibility of the client!!!

The indicated firing temperatures are only APPROXIMATE VALUES!!!

Warning for Investment Material:

The investment material contains quartz powder. AVOID inhaling dust, wear a protective mask and safety glasses. Read the warning on the investment packaging.

